



Air-Cooled Liquid Chillers with Integrated Hydronic Module

AQUASNAP™
with PURON® refrigerant



Model shown is with
low-noise option



Quality Management System Approval

30RB 182-802

Nominal cooling capacity 175-760 kW

The new generation of Aquasnap Puron liquid chillers features the latest technological innovations:

- ozone-friendly refrigerant R410A
- scroll compressors
- low-noise fans made of a composite material
- auto-adaptive microprocessor control.
- aluminium micro-channel heat exchangers (MCHX)

The Aquasnap can be equipped with an integrated hydronic module, limiting the installation to straightforward operations like connection of the power supply and the chilled water supply and return piping.

Features

Quiet operation

- Compressors
 - Low-noise scroll compressors with low vibration level
 - The compressor assembly is installed on an independent chassis supported by flexible anti-vibration mountings
 - Dynamic suction and discharge piping support, minimising vibration transmission (Carrier patent)
 - Acoustic compressor enclosure, reducing radiated noise emissions (option)

- Condenser section
 - Condenser coils in V-shape with an open angle, allowing quieter air flow across the coil
 - Low-noise 4th generation Flying Bird fans, made of a composite material (Carrier patent) are now even quieter and do not generate intrusive low-frequency noise
 - Rigid fan installation for reduced noise (Carrier patent)

Easy and fast installation

- Integrated hydronic module (option)
 - Centrifugal low or high-pressure water pump (as required), based on the pressure loss of the hydronic installation
 - Single or dual pump (as required) with operating time balancing and automatic changeover to the back-up pump if a fault develops
 - Water filter protecting the water pump against circulating debris
 - High-capacity membrane expansion tank ensures pressurisation of the water circuit
 - Thermal insulation and frost protection down to -20°C, using an electric resistance heater (see table of options)
 - Pressure gauge to check filter pollution and measure the system water flow rate
 - Water flow control valve

- Simplified electrical connections
 - A single power supply point without neutral (30RB 182-522)
 - Main disconnect switch with high trip capacity (see table of options)
 - 24 V control circuit without risk from a transformer included
- Fast commissioning
 - Systematic factory operation test before shipment
 - Quick-test function for step-by-step verification of the instruments, electrical components and motors

Economical operation

- Increased energy efficiency at part load
 - The refrigerant circuit includes several compressors connected in parallel. At part load, around 99% of the operating time, only the compressors that are absolutely necessary operate. At these conditions the compressors operating are even more energy efficient, as they use the total condenser and evaporator capacity.
 - The electronic expansion device (EXV) allows operation at a lower condensing pressure (EER optimisation).
 - Dynamic superheat management for better utilisation of the evaporator heat exchange surface.
 - All aluminium micro-channel condenser (MCHX), more efficient than a copper/aluminium coil
- Reduced maintenance costs
 - Maintenance-free scroll compressors
 - Fast diagnosis of possible incidents and their history via the Pro-Dialog Plus control
 - R410A refrigerant is easier to use than other refrigerant blends

Environmental care

- Ozone-friendly R410A refrigerant
 - Chlorine-free refrigerant of the HFC group with zero ozone depletion potential
 - High-density refrigerant, therefore less refrigerant required
 - Very efficient - gives an increased energy efficiency ratio (EER)
 - 40% reduction in the refrigerant charge through use of the micro-channel heat exchangers (MCHX)
- Leak-tight refrigerant circuit
 - Brazed refrigerant connections for increased leak-tightness
 - Reduction of leaks as no capillary tubes and flare connections are used
 - Verification of pressure transducers and temperature sensors without transferring refrigerant charge

Superior reliability

- State-of-the-art concept
 - Cooperation with specialist laboratories and use of limit simulation tools (finite element calculations) for the design of the critical components, e.g. motor supports, suction/discharge piping
 - Compressor control box installed on the cold side of the compressor (Carrier patent)
 - All-aluminium micro-channel heat exchanger (MCHX) offers 3.5 times higher corrosion resistance than a conventional coil. The all-aluminium construction eliminates the formation of galvanic currents between aluminium and copper that are responsible for the coil corrosion in saline or corrosive atmospheres.
- Auto-adaptive control
 - Control algorithm prevents excessive compressor cycling and permits reduction of the water quantity in the hydronic circuit (Carrier patent)
 - Automatic compressor unloading in case of abnormally high condensing pressure. If an anomaly occurs (e.g. fouled condenser coil, fan failure) Aquasnap continues to operate, but at reduced capacity.
- Exceptional endurance tests
 - Corrosion resistance tests in salt mist in the laboratory
 - Accelerated ageing test on components that are submitted to continuous operation: compressor piping, fan supports
 - Transport simulation test in the laboratory on a vibrating table. The test is based on a military standard and equivalent to 4000 km by truck.

Pro-Dialog Plus control

- Pro-Dialog Plus combines intelligence with operating simplicity. The control constantly monitors all machine parameters and precisely manages the operation of compressors, expansion devices, fans and of the evaporator water pump for optimum energy efficiency.
- Energy management
 - Internal time schedule clock: permits chiller on/off control and operation at a second set-point
 - Set-point reset based on the outside air temperature or the return water temperature
 - Master/slave control of two chillers operating in parallel with operating time equalisation and automatic change-over in case of a unit fault.
 - Start/stop control based on the air temperature
 - Ease-of-use
 - User interface with synoptic diagram for intuitive display of the principal operating parameters: number of compressors operating, suction/discharge pressure, compressor operating hours, set-point, air temperature, entering/leaving water temperature
 - Ten menus for direct access to all machine commands, including fault history, allowing fast and complete chiller diagnostics



Pro-Dialog Plus operator interface

Remote management (standard)

A simple two-wire communication bus between the RS485 port of the Aquasnap and the Carrier Comfort Network offers multiple remote control, monitoring and diagnostic possibilities. Carrier offers a vast choice of control products, specially designed to control, manage and supervise the operation of an air conditioning system. Please consult your Carrier representative for more information on these products.

- Start/stop: opening of this contact will shut down the unit
- Dual set-point: closing of this contact activates a second set-point (example: unoccupied mode)
- Demand limit: closing of this contact limits the maximum chiller capacity to a predefined value
- User safety: this contact is connected in series with the water flow switch and can be used for any customer safety loop
- Heat reclaim (option): closing of this contact allows heat reclaim mode operation
- Water pump 1 and 2 control*: these outputs control the contactors of one or two evaporator water pumps
- Water pump on reversal*: these contacts are used to detect a water pump operation fault and automatically change over to the other pump
- Operation indication: this volt-free contact indicates that the chiller is operating (cooling load) or that it is ready to operate (no cooling load)
- Alert indication: this volt-free contact indicates the presence of a minor fault
- Alarm indication: this volt-free contact indicates the presence of a major fault that has led to the shut-down of one or two refrigerant circuits

* contacts already supplied with the hydronic module option

Remote management (EMM option)

- Room temperature: permits set-point reset based on the building indoor air temperature (with Carrier thermostat)
- Set point reset: ensures reset of the cooling set-point based on a 4-20 mA or 0-5 V signal
- Demand limit: permits limitation of the maximum chiller demand based on a 4-20 mA or 0-5 V signal
- Demand limit 1 and 2: closing of these contacts limits the maximum chiller capacity to three predefined values
- User safety: this contact can be used for any customer safety loop, closing of the contact generates a specific alarm
- Ice storage end: when ice storage has finished, this input permits return to the second set-point (unoccupied mode)
- Time schedule override: closing of this contact cancels the time schedule effects
- Out of service: this signal indicates that the chiller is completely out of service
- Chiller capacity: this analogue output (0-10 V) gives an immediate indication of the chiller capacity
- Compressor operation: this contact signals that one or several compressors are in operation

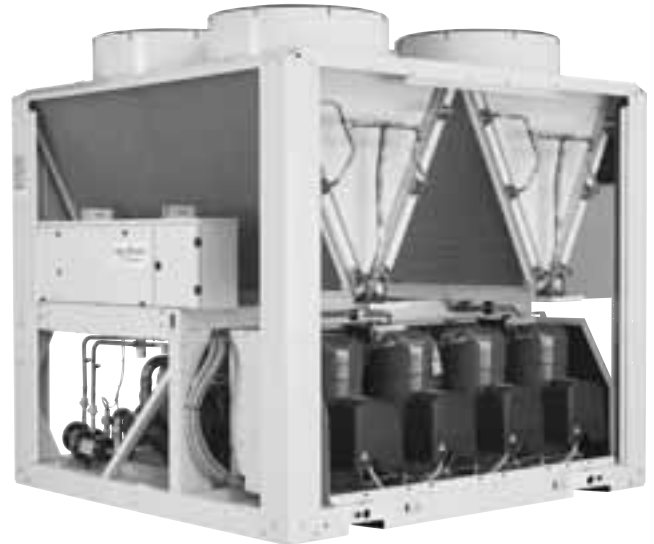

Already utilised in the automobile and aeronautical industries for many years, the MCHX heat exchanger is entirely made of aluminium. This one-piece concept significantly increases its corrosion resistance by eliminating the galvanic currents that are created when two different metals (copper and aluminium) come into contact in traditional heat exchangers. Unlike traditional heat exchangers the MCHX heat exchanger can be used in moderate marine and urban environments.

From an energy efficiency point-of-view the MCHX heat exchanger is approximately 10% more efficient than a traditional coil and allows a 40% reduction in the amount of refrigerant used in the chiller. The low thickness of the MCHX reduces air pressure losses by 50% and makes it less susceptible to fouling (e.g. by sand) than a traditional coil. Cleaning of the MCHX heat exchanger is very fast using a high-pressure washer.

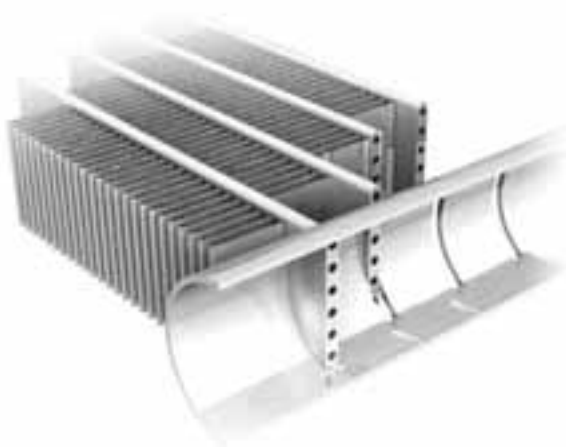

All aluminium micro-channel heat exchanger (MCHX)

Options and accessories

Options	Description	Advantages	Use
Connection sleeve	Piping to be welded with Victaulic connection	Ease-of-installation	30RB 182-802
Energy Management Module EMM	See controls manual	Easy connection by wired connection to a building management system	30RB 182-802
Scrolling Marquee Interface	Remotely installed user interface (communication bus)	Remote chiller control up to 300 m	30RB 182-402
Power cable connection side extension	Side extension on the power control to allow a reduced cable bend radius	Use of thicker power cables	30RB 302-802

Physical data

30RB		182	202	232	262	302	342	372	402	432	462	522	602	672	732	802
Nominal cooling capacity*	kW	173	193	227	263	293	328	359	391	418	447	506	596	652	704	758
Seasonal energy efficiency ratio (ESEER)	kW/kW	3.71	3.74	4.30	3.86	3.96	3.94	4.08	3.93	3.92	3.86	3.77	4.09	4.00	3.96	3.91
Operating weight**																
Unit with option 15	kg	2082	2172	2202	2370	2990	3186	3234	3370	3922	4062	4240	5480	5658	6370	6550
Standard unit	kg	1902	2002	2012	2180	2760	2956	2984	3110	3632	3772	3930	5120	5289	5960	6120
Refrigerant		R410A														
Circuit A	kg	11.4	11.4	14.5	14.5	20	21	21	20.5	26	26.5	26.5	23	23	28	28
Circuit B	kg	13.5	13.5	14	14	14	14	21	21.5	22	21.5	27.5	23	22.5	30	30
Circuit C	kg	-	-	-	-	-	-	-	-	-	-	-	24	28	25	33
Compressors		Hermetic scroll, 48.3 r/s														
Circuit A		1	1	2	2	3	3	3	3	4	4	4	3	3	4	4
Circuit B		2	2	2	2	2	2	3	3	3	3	4	3	3	4	4
Circuit C		-	-	-	-	-	-	-	-	-	-	-	3	4	3	4
No. of control stages		3	3	4	4	5	5	6	6	7	7	8	9	10	11	12
Minimum capacity	%	28	33	25	25	18	20	15	17	13	14	13	11	10	9	8
Control		Pro-Dialog Plus														
Condensers		Grooved copper tubes and aluminium fins														
Fans		Axial FLYING BIRD IV with rotating shroud														
Quantity		4	4	4	4	5	5	6	6	7	7	8	9	10	11	12
Total air flow	l/s	18056	18056	18056	18056	22569	22569	27083	27083	31597	31597	36111	40625	45139	49653	54167
Speed	r/s	16	16	16	16	16	16	16	16	16	16	16	16	16	16	16
Evaporator		Direct expansion, shell-and-tube														
Water volume	l	120	120	110	110	110	125	125	125	113	113	113	284	284	284	284
Max. water-side operating pressure without hydronic module	kPa	1000	1000	1000	1000	1000	1000	1000	1000	1000	1000	1000	1000	1000	1000	1000
Water connections (without hydronic module)		Victaulic														
Diameter	in	3	3	3	3	4	4	4	4	6	6	6	6	6	6	6
Outside tube diameter	mm	88.9	88.9	88.9	88.9	114.3	114.3	114.3	114.3	168.3	168.3	168.3	168.3	168.3	168.3	168.3

* Nominal conditions: evaporator entering/leaving water temperature 12°C/7°C, outside air temperature 35°C, evaporator fouling factor 0.18 x 10⁻⁴ (m² K)/W

** Weights are for guidance only

Sound levels

30RB		182	202	232	262	302	342	372	402	432	462	522	602	672	732	802
Unit with very low noise level option																
Sound power level 10 ⁻¹² W*	dB(A)	84	84	85	85	86	86	87	87	88	88	88	89	89	89	90
Sound pressure level at 10 m**	dB(A)	52	52	53	53	54	54	55	55	55	55	56	56	57	57	57
Unit with low noise level option																
Sound power level 10 ⁻¹² W*	dB(A)	89	89	89	89	90	90	91	91	92	92	92	93	94	93	94
Sound pressure level at 10 m**	dB(A)	57	57	57	57	58	58	59	59	60	60	60	61	61	61	62
Standard unit																
Sound power level 10 ⁻¹² W*	dB(A)	91	91	91	91	92	92	93	93	94	94	94	95	95	96	96
Sound pressure level at 10 m**	dB(A)	59	59	59	59	60	60	61	61	62	62	62	62	63	63	64

* In accordance with ISO 9614-1 and certified by Eurovent

** Average sound pressure level, unit in a free field on a reflective surface

Electrical data

30RB (without hydronic module)		182	202	232	262	302	342	372	402	432	462	522	602	672	732	802
Power circuit																
Nominal power supply	V-ph-Hz	400-3-50														
Voltage range	V	360-440														
Max. connectable power cable section																
Circuit A+B or	mm ²	1x240	1x240	1x240	1x240	2x240	2x240	2x240	2x240	3x240	3x240	3x240	2x240	2x240	3x240	3x240
Circuit C	mm ²	-	-	-	-	-	-	-	-	-	-	-	2x185	2x185	2x185	2x185
Control circuit supply																
24 V, via internal transformer																
Maximum unit power input*																
Circuit A+B	kW	85	98	102	127	140	159	172	191	204	223	255	191	191	255	255
Circuit C	kW	-	-	-	-	-	-	-	-	-	-	-	96	127	96	127
Nominal unit current draw**																
Circuit A+B	A	113	129	135	167	185	209	226	251	269	293	334	251	251	334	334
Circuit C	A	-	-	-	-	-	-	-	-	-	-	-	125	167	125	167
Maximum unit current draw***																
Circuit A+B	A	146	168	175	219	241	274	296	329	351	384	438	329	329	439	438
Circuit C	A	-	-	-	-	-	-	-	-	-	-	-	164	219	164	219
Maximum start-up current, standard unit†																
Circuit A+B	A	353	375	348	426	448	481	502	535	557	590	645	535	535	645	645
Circuit C	A	-	-	-	-	-	-	-	-	-	-	-	371	426	371	426
Cosine phi, unit at nom. capacity																
0.84 0.84 0.84 0.84 0.84 0.84 0.84 0.84 0.84 0.84 0.84 0.84 0.84 0.84 0.84 0.84 0.84																
Max. start-up current, unit with soft starter (UN)††																
Circuit A+B	A	283	305	277	356	378	411	433	466	489	521	575	-	-	-	-
Circuit C	A	-	-	-	-	-	-	-	-	-	-	-	-	-	-	-
Stability for three-phase short circuits (TN system)																
Unit with main disconnect without fuse†††																
Short-time current (1 s) - rms/peak value																
Circuit A+B	kA/kA	13/26	13/26	13/26	13/26	13/26	13/26	13/26	13/26	15/30	15/30	15/30	13/26	13/26	15/30	15/30
Circuit C	kA/kA	-	-	-	-	-	-	-	-	-	-	-	13/26	13/26	13/26	13/26
Unit with main disconnect with fuse‡																
Current value, rms, circuit A+B																
kA NA NA NA NA 50 50 50 50 50 50 50 50 50 50 50 50																
Current value, rms, circuit C																
kA - - - - - - - - - - - - 50 50 50 50																

* Power input of the compressor(s) + fan(s) at maximum unit operating conditions. Values given on the unit name plate.

** Nominal unit current draw at nominal conditions: evaporator entering/leaving water temperature 12°C/7°C, outdoor air temperature 35°C. The current values are given at 400 V nominal voltage.

*** Maximum unit operating current at maximum unit power input and 400 V.

† Maximum instantaneous starting current at 400 V nominal voltage and operating limit values with compressor in across-the-line start (maximum operating current of the smallest compressor(s) + fan current + locked rotor current of the largest compressor).

†† Standard for 30RB 182 to 262 and option for 30RB 302 to 802

‡ Not available for 30RB 182 to 262 and option for 30RB 302 to 802

Note: Units 30RB 602-802 have two electrical connection points.

Operating limits

Evaporator water flow rate

30RB	Min. water flow (l/s)	Max. water flow* (l/s)
182	2.8	28.1
202	2.8	28.1
232	3	26.7
262	3.5	26.7
302	3.9	26.7
342	4.4	29.4
372	4.9	29.4
402	5.2	29.4
432	5.8	31.1
462	6.1	31.1
522	6.9	31.1
602	7.9	50.6
672	8.7	50.6
732	9.6	50.6
802	10.3	50.6

* Maximum flow rate for an evaporator pressure drop of 100 kPa (unit with hydronic module)

Evaporator water temperature

	°C	Minimum	Maximum
Entering water temperature at shut-down	-	-	48
Entering water temperature at start-up	6.8	6.8	40
Entering water temperature during operation	6.8	6.8	25
Leaving water temperature during operation	3.3	3.3	15

Condenser air temperature

	°C	Minimum	Maximum
Standard unit	0	0	48
With winter operation option (No. 28)	-20	-20	48
With winter operation option (No. 28B)	-10	-10	48

Operating range

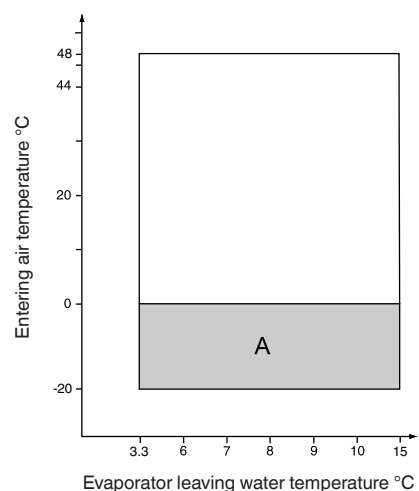

Notes:

1. Evaporator $\Delta T = 5$ K
 2. The evaporator must be protected against frost (frost protection option or anti-freeze solution).
- A. Operating range with winter operation option

Dimensions/clearances

30RB 182-262

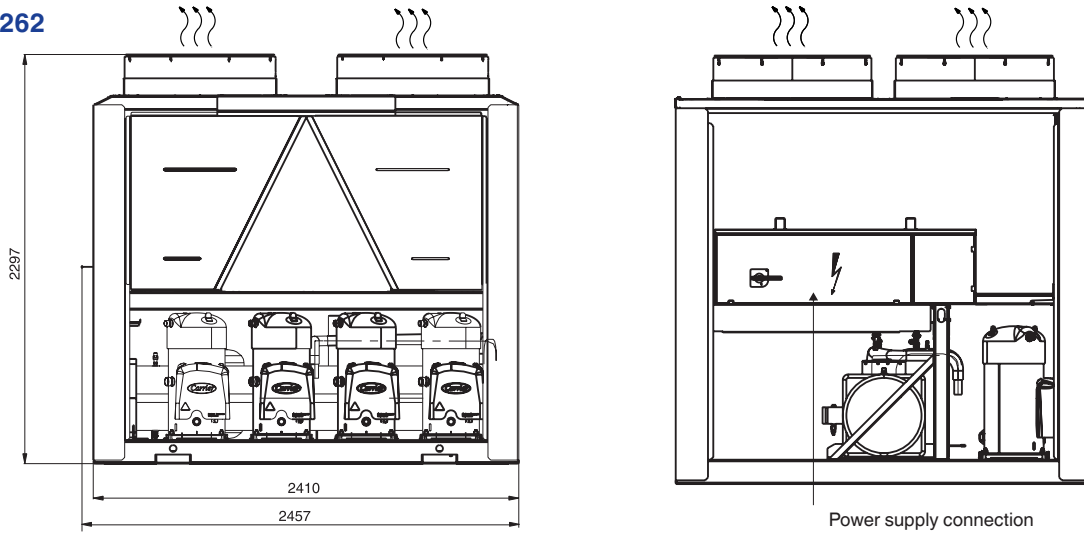

Unit with hydronic module

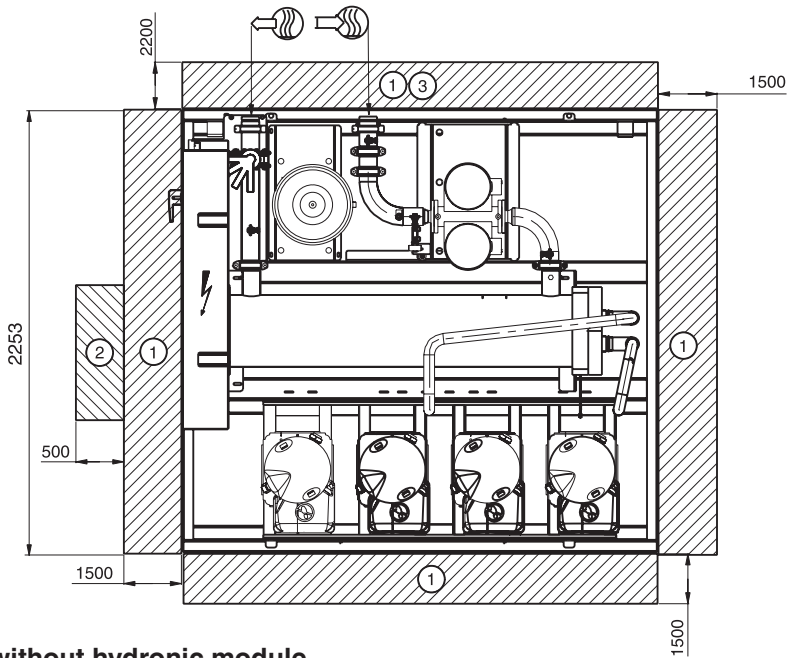

Legend:
All dimensions are given in mm.

- ① Required clearances for maintenance and air flow
- ② Recommended space for evaporator tube removal
- ③ Recommended space for coil removal



Water inlet



Water outlet

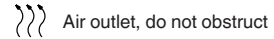

Air outlet, do not obstruct

Unit without hydronic module

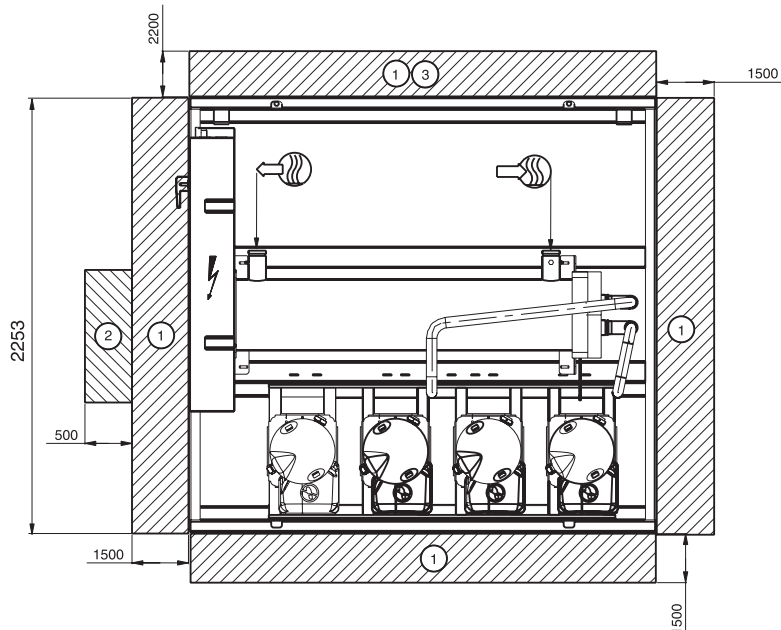

NOTE:
Drawings are not contractually binding. Before designing an installation, consult the certified dimensional drawings, available on request.